



INSTRUCTION SHEET

**RF DIRECTIONAL THRULINE[®]
POWER SENSOR
SERIES 5010**



根网通讯设备(北京)有限公司

邮件: enquiry@rootscomm.com.cn

网址: www.rootscomm.com.cn

ROOTS Communication Equipment (Beijing) Co.,Ltd.

北京市朝阳区芳园西路5号 丽园中心508室 100015

电话: +86-10-64382686

传真: +86-10-64382703

About this Instruction Sheet

This instruction sheet covers the following 5010 Series sensors:

- 5010B
- 5010T

Connecting Sensor

CAUTION

Do not connect or disconnect sensor interface cable to the DPS while the power meter is on. Always turn off the power meter before connecting or disconnecting a sensor.

Although unlikely, it is possible to corrupt the firmware in the power sensor (DPS) by connecting it to a power meter, such as the Bird Model 5000 (DPM) or a Bird Site Analyzer (SA), while the power meter is turned on. To prevent this, turn the power meter off before connecting it to the sensor. When you are done making measurements, turn the power meter off before disconnecting the sensor.

 NOTE: The 5010B sensor requires a DPM-EX with firmware version 5.17 or later or an SA with firmware version 08-June-2004 or later. For the latest firmware upgrades, contact Bird Customer Service at (440) 248-1200 or visit our website at <http://www.bird-electronic.com>

Element Orientation

WARNING

Leaking RF energy is a potential health hazard.
DO NOT connect or disconnect equipment from the transmission line while RF power is being applied. Severe burns, electrical shock, or death can occur.

The forward element and the reflected element must be of the same series (APM or 43). The power rating of the forward element must be 10x the power rating of the reverse element.

Insert the forward element into the forward socket with its arrow pointing in the direction of forward power. Insert the reflected element into the reflected socket with its arrow pointing in the direction of reverse power.

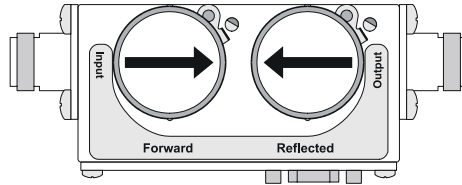

Element Contact Alignment

Continuous insertion or rotation of the element might cause a slight change in the position of the contact spring in the element socket. If the contact spring changes position, you might experience erratic power readings.

The position of the contact spring may be adjusted with a small screwdriver to reestablish contact.

CAUTION

If the element cannot be fully inserted into the socket, do not force it. You might damage the element.

Perform the following steps to adjust the contact spring:

1. Using a small flat head screwdriver, place the flat side of the screwdriver behind the contact bar as indicated and bend the contact bar so that the contact rests in the center of the slot adjacent to the element socket.

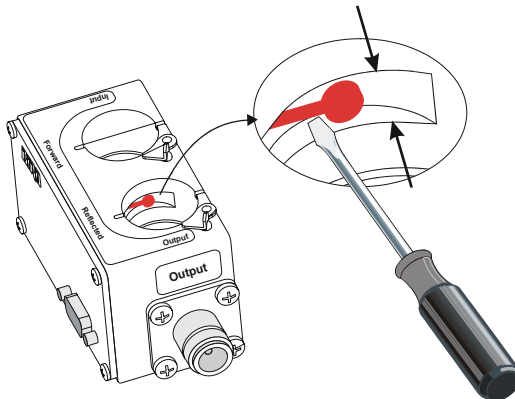

- After centering the contact, bend the contact bar slightly toward the center of the element socket bore, so that the profile of the element contact is visible when viewing the element socket from the top of the socket bore.

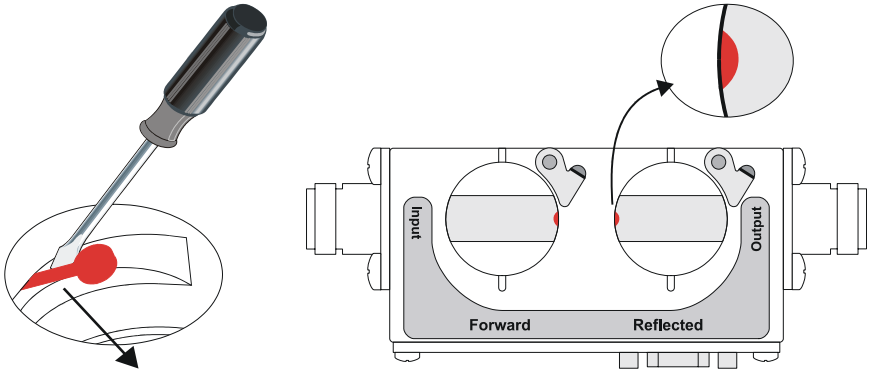

- If the contact is accidentally moved too far, the element will not slide into the socket. Move the contact back into the recessed area and repeat the process.

Specifications

Sensor Type	Thru-line two-element line section
Elements	Select two elements from the same series, with RFL power 1/10 of FWD power.
5010B	APM or 43 series elements
5010T	APM elements <i>only</i>
Frequency Range*	2 – 3600 MHz
Average Power Measurement, APM Elements , Forward or Reflected Direction	
Power Measurement Range*	0.1 W to 1 kW
Uncertainty†	± 5% of reading (95% c.l.)
Peak/Average Ratio, Max	10 dB
Detector Response (5010T only)	230 ms

Average Power Measurement, 43 Elements , Forward or refelected Direction	
Power Measurement Range	0.1 W to 10 kW
Power Measurement Uncertainty	± 5% of full scale average power (95% c.l.)
Peak Power Measurement, 43 Elements only , Forward direction only	
Pulse Width, Min	
2 – 25 MHz	15 µs
25 – 100 MHz	1.5 µs
> 100 MHz	800 ns
Rep. Rate, Min	15 pps
Duty Cycle, Min	1 x 10 ⁻⁴
Uncertainty [†]	± 8% of full-scale peak envelope power (95% c.l.)
Match Measurement	
Match Range	
Return Loss	0 to 20 dB
Rho (ρ)	0.1 to 1
VSWR	1.22 to 99.99
Uncertainty	Twice the Avg Power Uncertainty (Calculated from forward and reflected uncertainty)
Settling Time, Max	2.5 seconds
Impedance, Nominal	50 ohms
Insertion Loss, Max	0.05 dB up to 1 GHz
Input VSWR, Max.	1.05:1 up to 1 GHz
Directivity, Typical*	30 dB
RF Connectors	QC Type (N(F) normally supplied)
Power Supply	From host instrument via cable
Mechanical Shock and Vibration	In accordance with MIL-PRF-28800F Class 3
CE	CE compliant. Refer to DOC for specific standards.
Recommended Calibration Interval	1 year
Temp, Operating	-10 to +50 °C (+14 to +122 °F)
Temp, Storage	-40 to +75 °C (-40 to +167 °F)

Humidity, Max	95% (non-condensing)
Altitude, Max	3,000 m (10,000 ft.)
Dimensions, Nominal	5.0" x 2.4" x 2.0" (130 x 60 x 50 mm)
Weight, Nominal	0.9 lb. (0.4 kg)

- * Exact value depends on element selected
- † Above 35 °C or below 15 °C add 2%

