

PPM-350B

NETWORK TESTING—OPTICAL



The market's first BPON/EPON/GPON power meter

- New PPM-352B-EG model: the only power meter truly optimized for EPON and GPON architectures
- Pass/warning/fail indicators (10 threshold sets) for easy assessment of power values—anywhere on the network
- Simultaneous measurement and display of all PON signals—voice, data and video
- Filtered measurements, providing distinct power values for each signal (1310 nm, 1490 nm and 1550 nm)
- Available in two-port pass-through configurations* enabling full OLT-to-ONT communication while testing, as well as in one-port configurations
- The most easy-to-use instrument of its kind: simply connect the fiber and read the results
- Extended-range option for testing at the central office (CO) and before the splitter
- Go-anywhere versatility: enables quick, accurate testing all across the network



**Subject of international (PCT) application no. WO 2005/036783
and US application no. 2006/0171711.*

A Revolutionary Testing Tool for FTTH and FTTP Systems



The PPM-352B-EG two-port power meter.

The industry's first PON-specific power meter, the PPM-350B is the flagship of EXFO's line of test instruments specifically intended for FTTH and FTTP systems. Available in four models, the PPM-351B, PPM-352B, PPM-352B-EG and PPM-352B-EG-ER, it is the ideal tool for FTTH/FTTP service activation and troubleshooting.

Service Activation Testing

Optimizing network reliability requires that all PON signals be measured all the way through service activation to ensure they meet established standards. The PPM-350B offers the features to address this need:

- Pass-through connection for ONT signal measurement and simultaneous measurement of all PON signals
- Filtered detectors for individual measurement of each wavelength
- Upstream burst detection at 1310 nm



The PPM-350B's threshold configuration software interface.

Troubleshooting Testing

Throughout the maintenance phase, various transmission problems—fiber cuts, damaged/dirty connectors, macrobendings, optical transmitter failure, etc.—may ultimately cause signal loss or degradation. Benefit from the PPM-350B's troubleshooting functionalities:

- Quick, on-site test and measurement of PON signals, anywhere on the network
- Fault identification and isolation

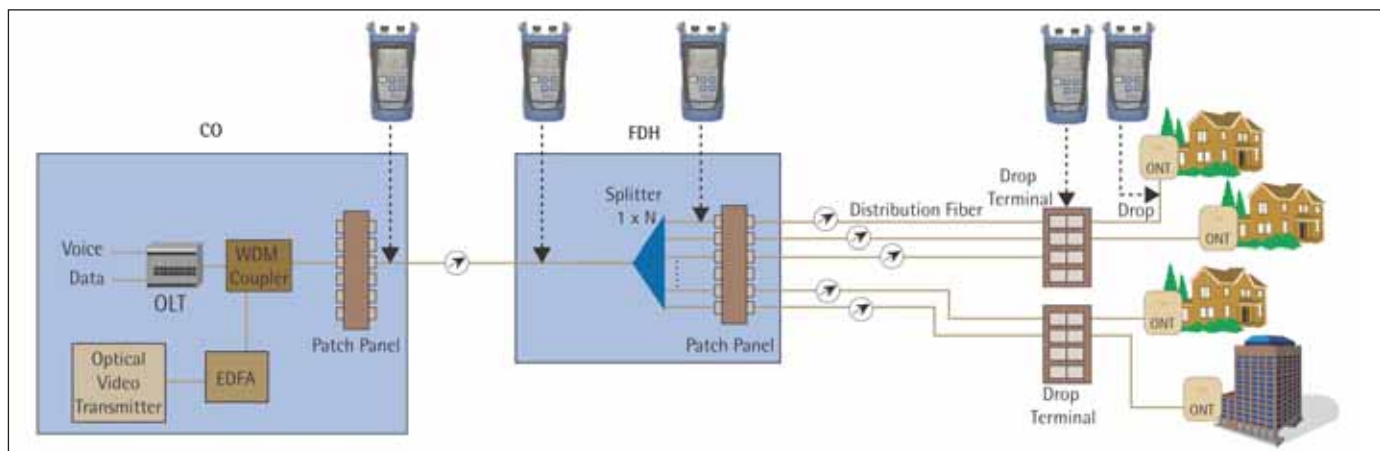

The PPM-350B is a choice solution for service activation and maintenance of all PON architectures within a network.

Upstream Burst Detection—Not To Be Taken Lightly

Correctly measuring PON signals can be a challenging task: not only can a single fiber carry up to three signals, but the upstream signal coming from the ONT operates in burst mode, which means that it is only active during its “allowed” timeslot. This is true whether the network is based on the BPON, EPON or GPON technology. Moreover, the timeslot is shorter in higher-speed networks such as EPON and GPON. Designed with this in mind, the PPM-350B PON Power Meter delivers accurate results for burst signals.

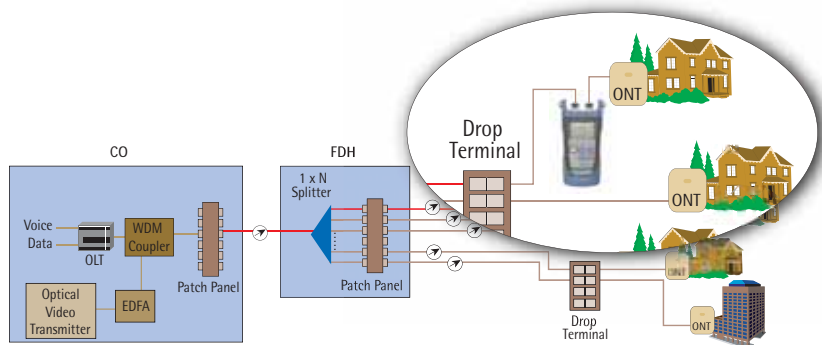

The PPM-350B allows for pass-through connection in any PON architecture.

Groundbreaking Technology—Two-Port Pass-Through*

The PPM-352B two-port model acts as a pass-through device, which means that it is connected between the OLT and the ONT. A small percentage of the signal is extracted for use by the power meter's detectors.

This approach enables all wavelengths to be used simultaneously. Also, since the PON equipment can keep functioning normally, the ONT continues to operate (to respond to the OLT), and therefore to transmit and have its laser on.

Up to 10 User-Definable Threshold Sets

Depending on the location of the test and the type of equipment used, different threshold values can be required. The PPM-350B enables you to select from up to 10 threshold sets—each set consisting of three wavelengths (1310, 1490 and 1550 nm) having their own pass, warning and fail thresholds. These values can be configured via the HHDT PC-based software.

AVAILABLE CONFIGURATIONS

| Options | PPM-351B | PPM-352B-EG | PPM-352B-EG-ER |
|----------------------------------------------------------------------------------------|----------|-------------|----------------|
| Two-port pass-through: all wavelengths; upstream measurement | | X | X |
| Downstream OLT signal (1490 nm) for up to 2.5 Gb/s | X | X | X |
| Downstream RF video signal (1550 nm) | X | X | X |
| Upstream BPON ONT signal for up to 622 Mb/s, as per ITU 983 (A, B, C) | | X | X |
| Upstream EPON and GPON ONT signal for up to 1.25 Gb/s, as per ITU 984 and IEEE 802.3ah | | X | X |
| Extended range for testing over the entire BPON, EPON or GPON architecture | | | X |



The PPM-350B's display.



The PPM-352B used at the ONT.

*Subject of international patent application no. WO 2005/036783.

SPECIFICATIONS^a

| | | PPM-351B | PPM-352B-EG | PPM-352B-EG-ER | |
|----------------------------------------------------------------------|---------|------------------------------------------------------|------------------|------------------------|-----------|
| | | | | BPON | EPON/GPON |
| Power measurement range – pass zone for continuous data stream (dBm) | 1310 nm | 5.5 to –15 | 5.5 to –24 | 10 to –40 | |
| | 1490 nm | 1 to –33 | 1 to –33 | 12 to –40 | |
| | 1550 nm | 15 to –36 | 15 to –36 | 25 ^b to –40 | |
| Burst mode measurement capability: | | Splitter to ONT | Splitter to ONT | CO to ONT | |
| Burst mode measurement range ^b (dBm) | 1310 nm | 5.5 to –15 | 5.5 to –24 | 10 to –33 | 10 to –29 |
| ORL ^c (dB) | 1550 nm | 55 | 55 | 55 | |
| Pass through insertion loss ^b (dB) | | 1.5 | 1.5 | 1.5 | |
| Spectral passband (nm) | 1310 nm | 1260 to 1360 | 1260 to 1360 | 1260 to 1360 | |
| | 1490 nm | 1480 to 1500 | 1480 to 1500 | 1480 to 1500 | |
| | 1550 nm | 1539 to 1565 | 1539 to 1565 | 1539 to 1565 | |
| Power uncertainty at calibrated wavelengths ^{b, d} (dB) | | 0.5 | 0.5 | 0.5 | |
| Refresh rate of display (Hz) | | 2.5 | 2.5 | 2.5 | |
| Calibrated wavelengths (nm) | | 1310, 1490, 1550 | 1310, 1490, 1550 | 1310, 1490, 1550 | |
| Threshold sets | | 10 configurable threshold sets with threshold naming | | | |
| Autonomy ^b (hours) | | > 30 | > 30 | > 30 | |
| Number of ports | | 1 | 2 | 2 | |
| Warranty and recommended calibration interval (year) | | 1 | 1 | 1 | |

Notes

- At room temperature.
- Typical.
- For APC connectors. Typically > 35 dB for UPC connectors.
- Around –7 dBm, CW.

GENERAL SPECIFICATIONS

| | | |
|-------------------|----------------------------|------------------------------|
| Size (H x W x D) | 185 mm x 100 mm x 55 mm | (7 1/4 in x 4 in x 2 1/8 in) |
| Weight | 0.4 kg | (0.9 lb) |
| Temperature | | |
| operating | –10 °C to 50 °C | (14 °F to 122 °F) |
| storage | –40 °C to 70 °C | (–40 °F to 158 °F) |
| Relative humidity | 0 % to 95 % non-condensing | |

STANDARD ACCESSORIES

User guide, three AA batteries, wrist strap, PC threshold-transfer software, RS-232 cable, alcohol cleaning pads.

ORDERING INFORMATION

PPM-35XB-XX

Model

PPM-351B = PON power meter, one port BPON
 PPM-352B-EG = PON power meter, two ports, BPON, EPON, GPON
 PPM-352B-EG-ER = PON power meter, two ports, BPON, extended range EPON, GPON

Connector^a

EI-EUI-28 = UPC/DIN 47256
 EI-EUI-76 = UPC/HMS-10/AG
 EI-EUI-89 = UPC/FC narrow key
 EI-EUI-90 = UPC/ST
 EI-EUI-91 = UPC/SC
 EI-EUI-95 = UPC/E-2000
 EA-EUI-28 = APC/DIN 47256
 EA-EUI-89 = APC/FC narrow key
 EA-EUI-91 = APC/SC
 EA-EUI-95 = APC/E-2000

Example: PPM-352B-EG-ER-EA-EUI-91

Notes

- Same connectors for both ports on two-ports version.

Rugged Handheld Solutions

| | |
|-----------------|--------------------------------------|
| OPTICAL | COPPER ACCESS |
| – OTDRs | – ADSL/ADSL2+, SHDSL, VDSL test sets |
| – OLTSs | – VoIP and IPTV test sets |
| – Power meters | – Ethernet test sets |
| – Light sources | – POTS test sets |
| – Talk sets | |

Platform-Based Solutions

| | | |
|------------------------|---------------------------------|---------------------------------------------|
| OPTICAL FIBER | DWDM TEST SYSTEMS | TRANSPORT AND DATA COM |
| – OTDRs | – OSAs | – Next Generation SONET/SDH and OTN testers |
| – OLTSs | – PMD analyzers | – SONET/DSn (DS0 to OC-192) testers |
| – ORL meters | – Chromatic dispersion analyzer | – SDH/PDH (64 kb/s to STM-64) testers |
| – Variable attenuators | | – T1/T3, E1 testers |
| | | – 10/100M and Gigabit Ethernet testers |
| | | – Fibre Channel testers |
| | | – 10 Gigabit Ethernet testers |



根网通讯设备(北京)有限公司
 邮件: enquiry@rootscmm.com.cn
 网址: www.rootscmm.com.cn
 ROOTS Communication Equipment (Beijing) Co.,Ltd.
 北京市朝阳区芳园西路5号 丽园中心508室 100015
 电话: +86-10-64382686
 传真: +86-10-64382703



Printed in Canada 06/12